



TEST REPORT

Report No.: H2466.08-801-44

Rendered to:

C.R. LAURENCE CO., INC.
Los Angeles, California

PRODUCT TYPE: Aluminum Side Hinged Twin Door
SERIES/MODEL: 500TC Thermal Composite Twin Door

Title	
	500TC Twin Door
Design Pressure	±2400 Pa (±50 psf)
Air Infiltration	4.6 L/s/m ² (0.92 cfm/ft ²) @ 75 Pa (1.57psf)

Test Completion Date: 07/13/2017

Reference must be made to Report No. H2466.04-801-47 dated 8/07/17 for complete test specimen description and detailed test results.

1.0 Report Issued To: C.R. Laurence Co., Inc.
2503 e. Vernon Ave.
Los Angeles, California 90058

2.0 Test Laboratory: Architectural Testing, Inc.,
an Intertek company ("Intertek-ATI")
1909 10th St. Suite 100
Plano, Texas 75074
(469) 814-0687

3.0 Project Summary:

3.1 Product Type: Aluminum Sided Hinged Twin Door

3.2 Series/Model: 500TC Thermal Composite Twin Door

3.3 Compliance Statement: Results obtained are tested values and were secured by using the designated test method(s). Test specimen description and results are reported herein.

This product was originally tested as the Oldcastle BuildingEnvelope® products series/model WS-500TC Thermal Composite Door and is a reissue of the original Report No. H2466.04-801-44. This report is reissued in the name of C.R. Laurence co., Inc. through written authorization by Oldcastle BuildingEnvelope®.

3.4 Test Dates: 07/13/17

3.5 Test Location: Intertek/ATI test facility in Plano, Texas.

3.6 Test Sample Source: The test specimen was provided by the client. Representative samples of the test specimen(s) will be retained by Intertek-ATI for a minimum of four years from the test completion date.

3.7 Drawing Reference: The test specimen drawings have been reviewed by Intertek/ATI and are representative of the test specimen(s) reported herein. Test specimen construction was verified by Intertek-ATI per the drawings located in Appendix A. Any deviations are documented herein or on the drawings.

3.8 List of Official Observers:

<u>Name</u>	<u>Company</u>
Phil Clark	Oldcastle BuildingEnvelope®
Jeffrey Crump	Intertek/ATI

4.0 Test Specification(s):

ASTM E 283-04, *Test Method for Determining Rate of Airflow Through Exterior Windows, Curtain Walls and Doors Under Specified Pressure Differences Across the Specimen.*

Florida Building Code, Energy Conservation, Commercial Energy Efficiency

ASTM E 330-02, *Test Method for Structural Performance of Exterior Windows, Curtain Walls and Doors by Uniform Static Air Pressure Difference.*

AAMA 1304-02, *Voluntary Specification for Forced Entry Resistance of Side-Hinged Door Systems.*

5.0 Test Specimen Description:

5.1 Product Sizes:

Overall Area: 2.08 m ² (22.4 ft ²)	Width		Height	
	millimeters	inches	millimeters	inches
Overall size	1880	74	2159	85
Leaf size	902	35-1/2	2115	83-1/4
Leaf Daylight Opening	673	26-1/2	1765	69-1/2
Leaf size	900	35-7/16	2115	83-1/4
Leaf Daylight Opening	673	26-1/2	1765	69-1/2

5.2 Frame Construction:

Frame Member	Material	Description
Head, jamb and threshold	Aluminum	Extruded aluminum thermally broken with thermal strut.

	Joinery Type	Detail
Head to jamb connections	Mechanical	Corners are square cut, end coped and mechanically fastened using frame shear block (part #AC13401) at the lock side interior and exterior. Header (part #FG3534) is connected to header shear block (part #AC13401) on the interior side with two (2) #10 x 3/8" PFH at each end and angle clip AN102 angle clip on the pivot side with two (2) #12 x 1/2" PFHUC). Corners sealed.
Threshold	Mechanical	Jambs are attached to threshold with clip (part#

(part #TH65) to jamb connections		TH6401). Threshold set in sealant and ends sealed.
Corner Connection	Mechanical	Corners are square cut, end coped and mechanically fastened, frame head (part #FG3534) connected with jambs with (2) #12 x 1/2" PFHUC. Horizontal intermediate (part #FG3575) shear block connected with four (4) #12 x 1/2" PFHUC, intermediate is connected to shear blocks with #10 x 3/8" PFH at each end. Corners sealed.

5.3 Leaf Construction:

Vent Member	Material	Description
Top rail, Bottom rail and stiles	Aluminum	Extruded aluminum.

	Joinery Type	Detail
All corners	Mechanical	Vertical door stile slots milled in mating surface with B140 corner block inserted through stile and into horizontal door rail. One (1), 1/4"-20 x 7/16" HWH Type F screw (part #10544) installed through the door stile into B140 to retain block to the vertical stile. Door corners are attached with two (2) #12-24 x 1.343" HWH Self Drilling Screws (FS-325) and fillet welds at corner to vertical stile.

5.4 Weather-stripping:

Description	Quantity	Location
Bulb Gasket (part #375TD125)	3	Full span at head and jamb door stops (part #TD105), interior face.
Sweep (part #GP305)	1	Attached to interior and exterior face of door bottom rail.
Rigid polypropylene plastic filler with Santoprene fin seal (GP300)		Inserted into jamb door stops (part #TD105) which contacts door vertical stile.

Rigid polypropylene plastic filler (GP302)	1	Inserted into head door stop (part #TD105) which fills in header pocket. Part GP302 runs long at each end to fill in jamb to head connection.
ABS plastic isolator	1	Interior of panel weather-strip insert
Weather-strip (375WP085)	2	Attached to the lateral face of the panel weather-strip insert.
Aluminum weather-strip insert	1	Attached to primary leaf interior lateral face with #8 x 3/4" screws/

5.0 Test Specimen Description: (Continued)

5.5 Glazing: *No conclusions of any kind regarding the adequacy or inadequacy of the glass in any glazed test specimen(s) can be made.*

Glass Type	Spacer Type	Interior Lite	Exterior Lite	Glazing Method
1" IG	Aluminum box	1/4" tempered	1/4" tempered	Secured with glass stops (part #TD103) with glazing gasket attached to stops

5.6 Drainage: Sloped threshold was utilized.

5.7 Hardware:

Description	Quantity	Location
Butt hinges (375TBH)	3	Located 7-1/2", 9-1/2" and one at center of frame jamb. Hinges attached with eight (8) # 12 x 1/2" screws at each jamb and panel rail location.
1-1/2" Backset Hook Bolt Lock (part #DH22900)	1	Located at the interior of door panel
HD flush bolt (part #DH008)	1	Located at the interior of door panel
Cylinder kit (part #375TLC)	1	
Push/Pull handle set (part #PR032/PR032)	2	Located at the interior and exterior of panel.

5.8 Reinforcement: No reinforcement was utilized.

6.0 Installation:

The specimen was installed into a Spruce-Pine-Fir wood buck. The rough opening allowed for a 1/8" shim space. The exterior perimeter of the window was sealed with sealant.

Location	Anchor Description	Anchor Location
Frame members and threshold	1/4"-20 x 2" HWH Type F screws	6" from each end and 4" off center at frame head, 12" from each end and one (1) at center of each jamb member. Two at each end of frame threshold.

7.0 Test Results: The temperature during testing was 23°C (74°F). The results are tabulated as follows:

Title of Test	Results	Allowed	Note
Air Leakage, Infiltration per ASTM E 283 at 75 Pa (1.57 psf)	3.1 L/s/m ² (0.62 cfm/ft ²)	5 L/s/m ² *(1.00 cfm/ft ²) max.	1
Uniform Load Deflection, per ASTM E 330 taken at hinges +2400 Pa (+50.00 psf) -2400 Pa (-50.00 psf)	<.1 mm (<0.01") 1 mm (0.04")	4.3 mm (0.17") max. 4.3 mm (0.17") max.	4
Uniform Load Deflection, per ASTM E 330 taken at lock rail +2400 Pa (+50.12 psf) -2400 Pa (-50.12 psf)	<.10 mm (<0.01") 2 mm (0.08")	6 mm (0.24") max. 6 mm (0.24") max.	4
Uniform Load Structural, per ASTM E 330 taken at hinges +3600 Pa (+75.19 psf) -3600 Pa (-75.19 psf)	<0.1 mm (<0.01") <0.1 mm (<0.01")	3 mm (0.12") max. 3 mm (0.12") max.	
Uniform Load Structural, per ASTM E 330 taken at lock rail +3600 Pa (+75.19 psf) -3600 Pa (-75.19 psf)	1.3mm (0.05") 2.8mm (0.11")	4.3 mm (0.17") max. 4.3 mm (0.17") max.	4

Title of Test	Results	Allowed	Note
Forced Entry Resistance, per AAMA 1304 300 lb test load	Pass	No entry	

** Florida Building Code, Energy Conservation, Commercial Energy Efficiency*

Note 1: The client opted to start at a pressure higher than the minimum required. Test results are reported under Optional Performance.

Note 2: Loads were held for 10 seconds.

Note 3: Tape and film were used to seal against air leakage during structural testing. In our opinion, the tape and film did not influence the results of the test.

The service life of this report will expire on the stated Test Record Retention End Date, at which time such materials as drawings, data sheets, samples of test specimens, copies of this report, and any other pertinent project documentation, shall be discarded without notice.

If test specimen contains glazing, no conclusions of any kind regarding the adequacy or inadequacy of the glass in any glazed test specimen(s) can be made. This report does not constitute certification of this product nor an opinion or endorsement by this laboratory. It is the exclusive property of the client so named herein and relates only to the specimen(s) tested. This report may not be reproduced, except in full, without the written approval of Intertek/ATI.

For Intertek-ATI:

Jeffrey Crump
 Sr. Project Manager

Andy Cost
 Laboratory Manager

JC:cm

Attachments (pages): This report is complete only when all attachments listed are included.
 Appendix-A: Drawings (7)

This report produced from controlled document template ATI 00506 issued 04/25/11.

Revision Log

<u>Rev. #</u>	<u>Date</u>	<u>Page(s)</u>	<u>Revision(s)</u>
0	08/30/18	NA	Reissue Report
1	09/11/18	4	Corrected part numbers

Appendix A

Drawings



Report #:	H2466.08-801-44
Date:	08/27/18
Verified by:	J. Crump

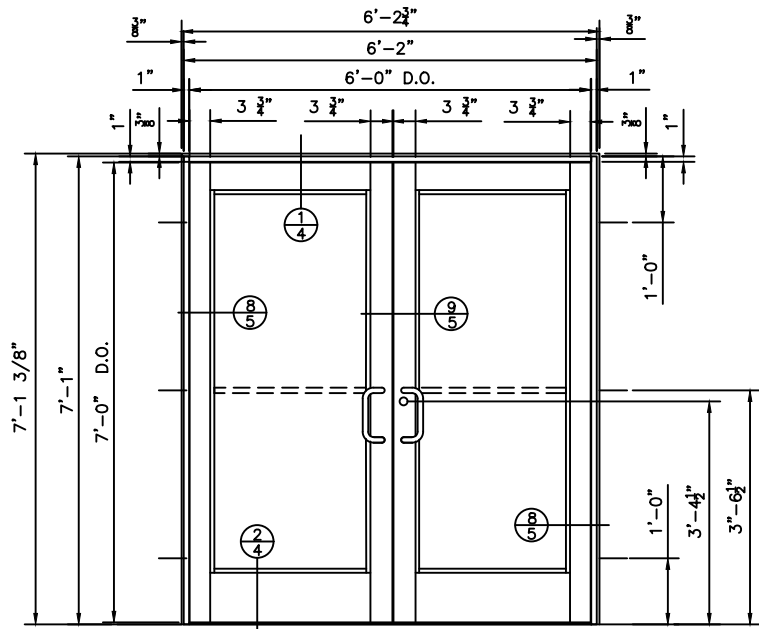

Test #1

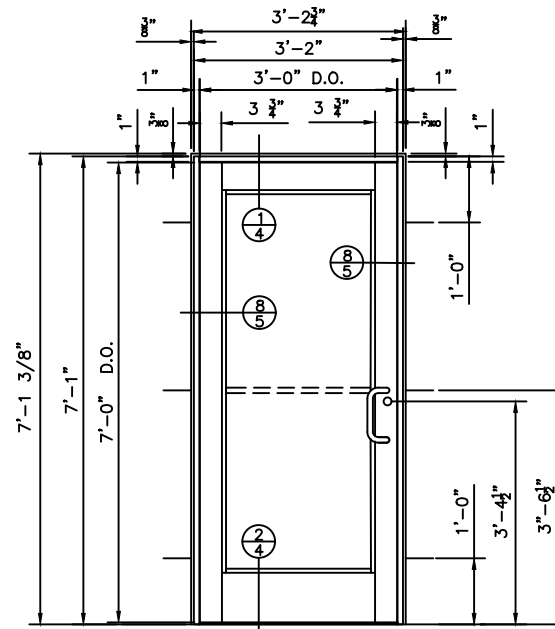

Test #2

Test #1: Pair Door	1.57 psf Air Test	50psf design	75psf structural	Forced Entry
Test #2 Single Door	1.57 psf & 6.24PSF Air Test	50psf design	75psf structural	Forced Entry

REVISIONS



C.R. LAURENCE CO.
 ARCHITECTURAL PRODUCTS
 2100 E. 38TH Street, Los Angeles, CA 90058
 www.crlaurence.com

Job Name:
 375TC / 500TC
 THERMAL COMPOSITE DOOR
 PERFORMANCE TESTING

Glazing Contractor:
 DATE: 6.25.2018
 DRAWN BY: GDO
 CHECKED BY: XX
 SCALE: AS SHOWN
 JOB #: PTC768309

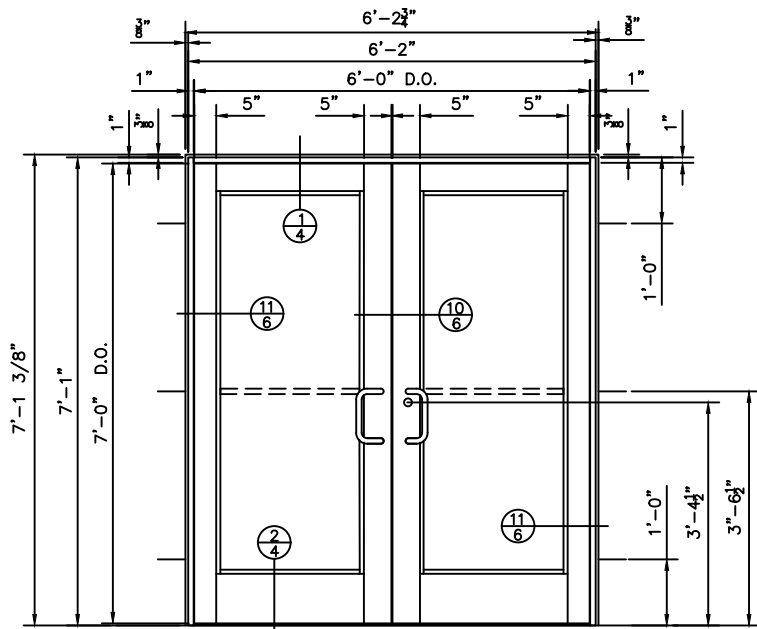

Test #3

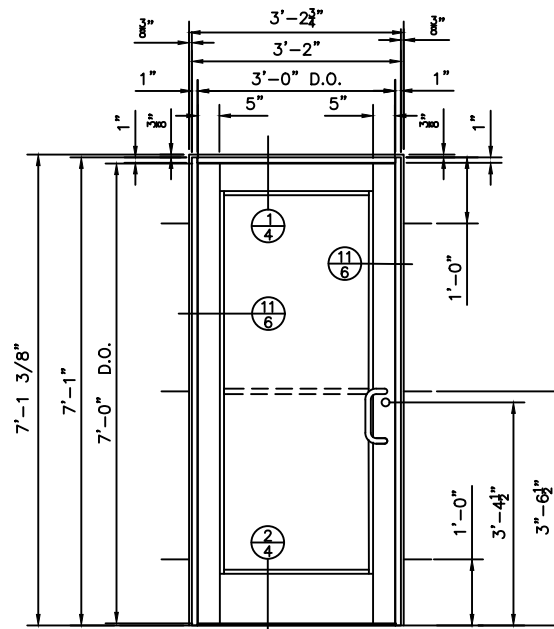

Test #4

Test #3: Pair Door	1.57 psf Air Test	50psf design	75psf structural	Forced Entry
Test #4 Single Door	1.57 psf & 6.24 Air Test	50psf design	75psf structural	Forced Entry



Report #:	H2466.08-801-44
Date:	08/27/18
Verified by:	J. Crump

REVISIONS



C.R. LAURENCE CO.
ARCHITECTURAL PRODUCTS
2100 E. 38TH Street, Los Angeles, CA 90058
www.crlaurence.com

375TC / 500TC
THERMAL COMPOSITE DOOR
PERFORMANCE TESTING

Job Name:

Glazing Contractor:

DATE:	6.25.2018
DRAWN BY:	GDO
CHECKED BY:	XX
SCALE:	AS SHOWN
JOB #:	PTC768309

375TC Hardware

Door Hardware Test # 1		
Qty:	Hardware #:	Description:
1-1/2 Pair per door	375TBH	Butt Hinges
1	DH22900	1-1/2" Back Set Hook Bolt Lock
1	DH008	H.D. Flush Bolt
2	PR032/PR034	Push/Pull
2	375TLC	Cylinder Kit
	375TG159	Bulb Gasket-Door Stops

Door Hardware Test # 2		
Qty:	Hardware #:	Description:
1 Set	OP-6, OP-7, OP-9, OP-10, OP-11	Offset Pivots
1	DH22900	1-1/2" Back Set Hook Bolt Lock
1	375TLC	Cylinder Kit
	PR032/PR034	Push/Pull
	375TG159	Bulb Gasket-Door Stops

500TC Hardware

Door Hardware Test # 3		
Qty:	Hardware #:	Description:
1-1/2 Pair per door	375TBH	Butt Hinges
1	DH22900	1-1/2" Back Set Hook Bolt Lock
1	DH008	H.D. Flush Bolt
2	PR032/PR034	Push/Pull
2	375TLC	Cylinder Kit
	375TG159	Bulb Gasket-Door Stops

Door Hardware Test # 4		
Qty:	Hardware #:	Description:
1 Set	OP-6, OP-7, OP-9, OP-10, OP-11	Offset Pivots
1	DH22900	1-1/2" Back Set Hook Bolt Lock
1	375TLC	Cylinder Kit
	PR032/PR034	Push/Pull
	375TG159	Bulb Gasket-Door Stops



Report #:	H2466.08-801-44
Date:	08/27/18
Verified by:	J. Crump

REVISIONS



C.R. LAURENCE CO.
ARCHITECTURAL PRODUCTS
2100 E. 38TH Street, Los Angeles, CA 90058
www.crlaurence.com

375TC / 500TC
THERMAL COMPOSITE DOOR

Job Name:

Glazing Contractor:

DATE: 6.25.2018
DRAWN BY: GDO
CHECKED BY: XX
SCALE: AS SHOWN
JOB #: PTC768309

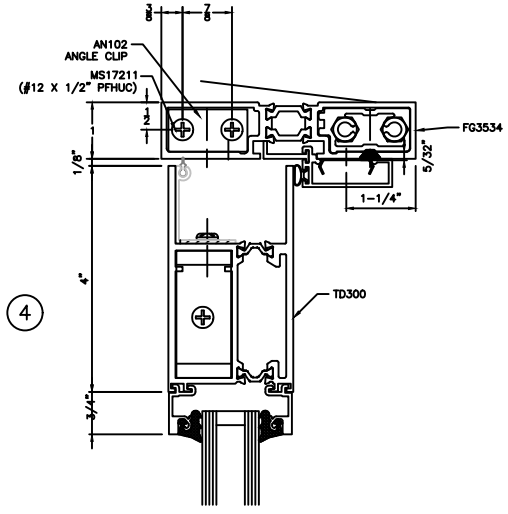
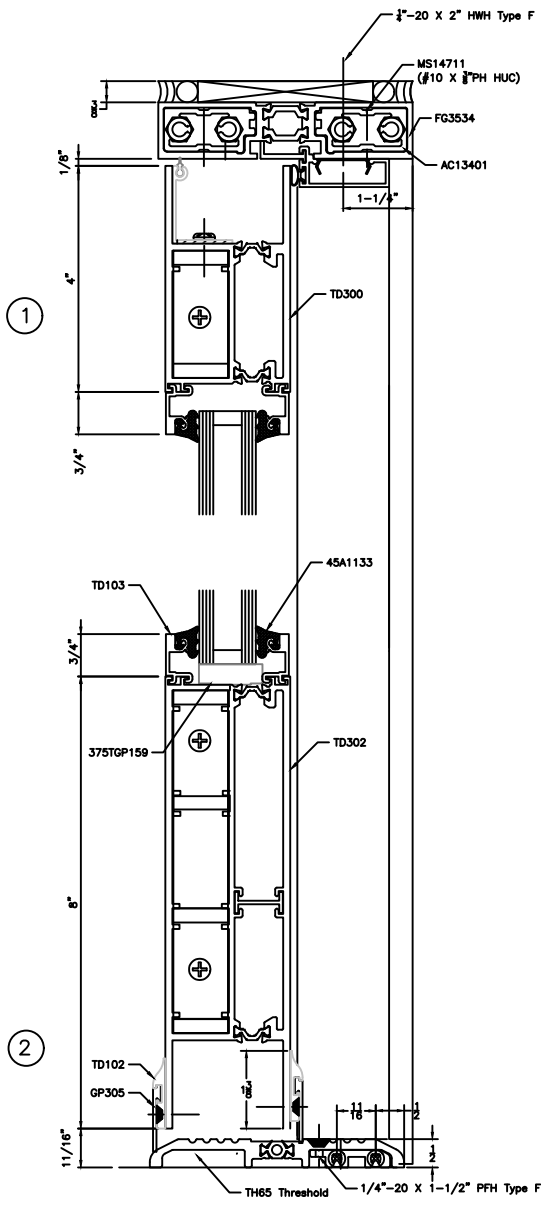

	Report #:	H2466.08-801-44
	Date:	08/27/18
	Verified by:	J. Crump

REVISIONS

C.R. LAURENCE CO.
 ARCHITECTURAL PRODUCTS
 2100 E. 38TH Street, Los Angeles, CA 90058
 www.crlaurence.com

Job Name:
 375TC
 THERMAL COMPOSITE DOOR

Glazing Contractor:

DATE:	6.25.2018
DRAWN BY:	GDO
CHECKED BY:	XX
SCALE:	AS SHOWN
JOB #:	PTC768309



C.R. LAURENCE CO.
 ARCHITECTURAL PRODUCTS
 2100 E. 38TH Street, Los Angeles, CA 90058
 www.crlaurence.com

intertek
 Total Quality Assured.

Report #:	H2466.08-801-44
Date:	08/27/18
Verified by:	J. Crump

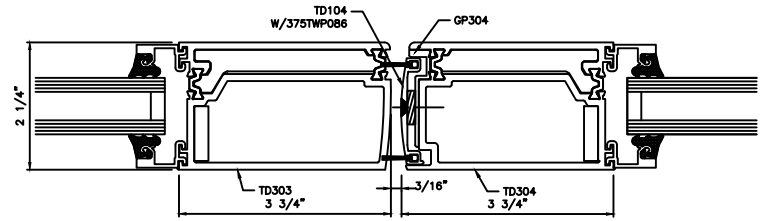
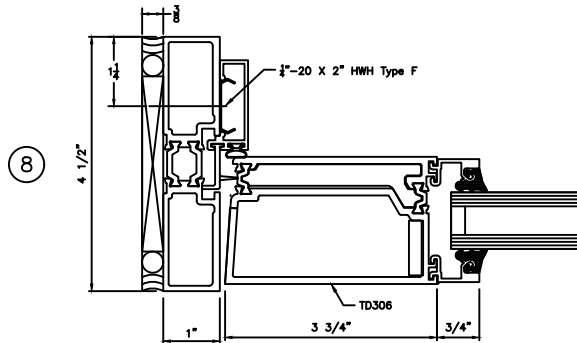

Job Name:

375TC
 THERMAL COMPOSITE DOOR

Gloazing Contractor:

DATE:	6.25.2018
DRAWN BY:	GDO
CHECKED BY:	XX
SCALE:	AS SHOWN
JOB #:	PTC768309

REVISIONS



CRL
 C.R. LAURENCE CO.
 ARCHITECTURAL PRODUCTS
 2100 E. 38TH Street, Los Angeles, CA 90058
 www.crlaurence.com

500TC
 THERMAL COMPOSITE DOOR

Job Name:

Glazing Contractor:

DATE: 6.25.2018
 DRAWN BY: GDO
 CHECKED BY: XX
 SCALE: AS SHOWN
 JOB #: PTC768309

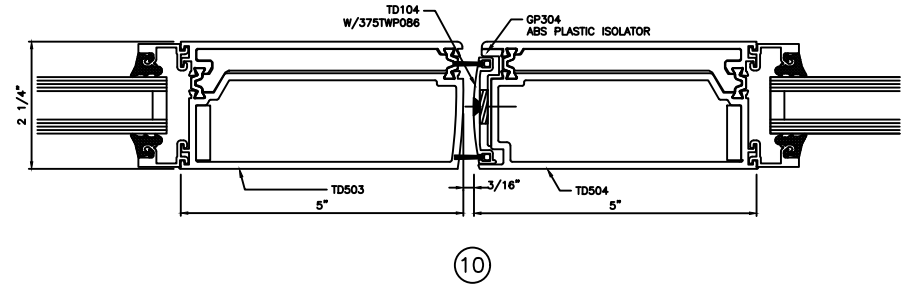
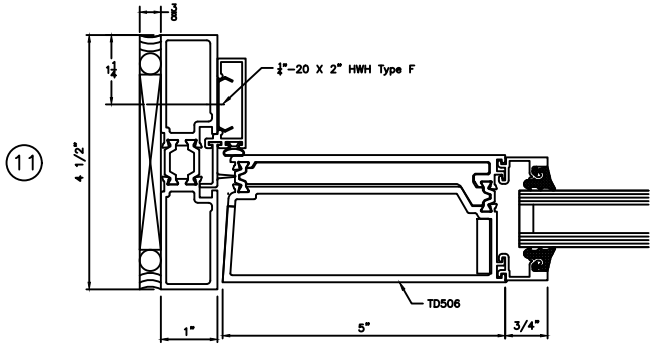

<p>Total Quality Assured.</p>	Report #:	H2466.08-801-44
	Date:	08/27/18
	Verified by:	J. Crump



TD105



TD100



TD103



TD102



TD104



FG3534

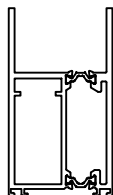

TD300

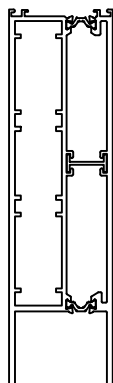

TD301

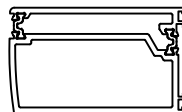

TD303

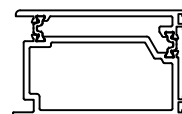

TD304



TD305



TD306

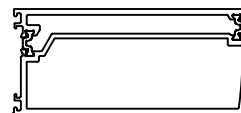

TD503

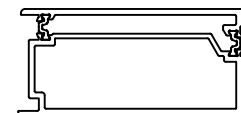

TD504

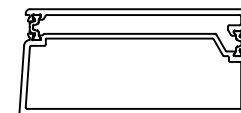

TD506



GP300



GP302



GP303



GP304



GP305



Total Quality. Assured.

Report #:	H2466.08-801-44
Date:	08/27/18
Verified by:	J. Crump

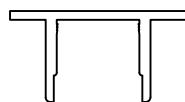

B140



TH65



AC134



AC130



TH64

REVISIONS



C.R. LAURENCE CO.
ARCHITECTURAL PRODUCTS
2100 E. 38TH Street, Los Angeles, CA 90058
www.crlaurence.com

375TC
THERMAL COMPOSITE DOOR

Job Name:

Glazing Contractor:

DATE:	6.25.2018
DRAWN BY:	GDO
CHECKED BY:	XX
SCALE:	AS SHOWN
JOB #:	PTC768309